

# UTRUSTA

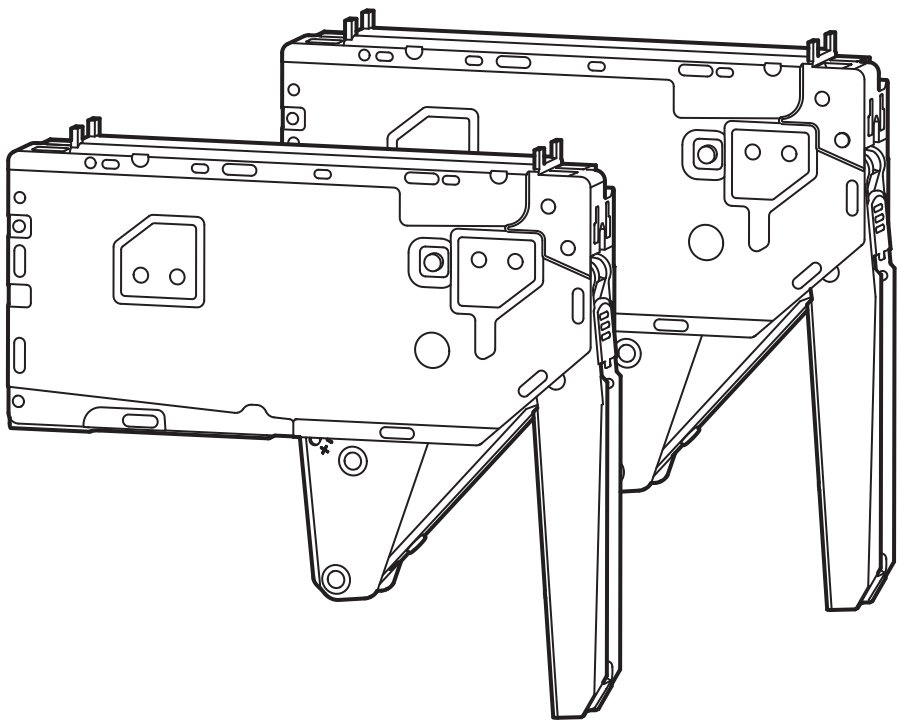

Design and Quality  
IKEA of Sweden

**English**

Warning!

Take care when handling this hinge as the spring is very strong and can cause injury.

**Deutsch**

Achtung! Bitte Vorsicht beim Umgang mit diesem Scharnier. Die stark gespannte Feder könnte zu Verletzungen führen.

**Français**

Attention !

Prenez garde lorsque vous manipulez cette charnière car le ressort est très tendu et risque d'occasionner des blessures.

**Nederlands**

N.B. Wees voorzichtig bij het monteren van deze scharnier. De veer is zeer krachtig en kan letsel veroorzaken.

**Dansk**

ADVARSEL!

Hængslet skal håndteres forsigtigt, da fjederen er meget stærk og kan forårsage personskade.

**Íslenska**

Viðvörðun!

Gætið varkárni þegar þessar lamir eru meðhöndlaðar því gormurinn er mjög sterkur og getur valdið meiðslum.

**Norsk**

Advarsel!

Vær forsiktig når du håndterer disse hengslene, ettersom fjæren er sterk og kan forårsake personskader.

**Suomi**

Varoituis!

Olethan varovainen käsitellessäsi tätä saranaa, sillä jousi on erittäin jäykkä ja voi aiheuttaa vammoja.

**Svenska**

Obs! Var försiktig när du handskas med det här gångjärnet. Fjädern är mycket kraftig och kan skada dig.

**Česky**

Upozornění!

S pantem zacházejte opatrně - pružina uvnitř je velice silná a může způsobit zranění.

**Español**

¡Atención!

Ten cuidado al manipular esta bisagra, porque el muelle está muy tensado y puede causar lesiones.

**Italiano**

Avvertenza! Fai attenzione quando maneggi questa cerniera: la molla è molto tesa e può rischiare di causare lesioni.

**Magyar**

Figyelem!

Óvatosan bánj a zsanérral, mert a rugó nagyon erős, és sérülést okozhat.

**Polski**

Ostrzeżenie!

Montując zawias zachowaj ostrożność, ponieważ sprężyna jest bardzo mocna i może powodować obrażenia.

**Eesti**

Hoiatus!

Olge ettevaatlik selle hinge käsitlemisel, vedru on väga tugev ja võib põhjustada vigastusi.



### **Latviešu**

Uzmanību!

Tā kā šīs enģes atsperes mehānisms ir ļoti spēcīgs, lai izvairītos no iespējamām traumām, rīkojieties ar to uzmanīgi.

### **lietuvių**

Įspėjimas!

Būkite atidūs dirbdami su šiais lankstais. Spyruoklė labai tamprī ir gali sužeisti.

### **Portugues**

Aviso!

Tenha atençāo ao manipular esta dobradiça pois a mola é muito forte e pode causar lesões.

### **Romāna**

Atenție!

Ai grijā când montezi balamaua pentru că arcul este foarte puternic și te poate răni.

### **Slovensky**

Upozornenie!

Pri zaobchádzaní s týmto pántom buďte opatrný, pretože pružina je veľmi silná a môže spôsobiť zranenie.

### **Български**

Внимание!

Бъдете предпазливи при работа с тази панта, тъй като пружината ѝ е много здрава и може да причини нараняване.

### **Hrvatski**

Upozorenje!

Pripazite prilikom rukovanja ovom šarkom. Opruga je jako čvrsta i može izazvati ozljede.

### **Ελληνικά**

Προειδοποίηση!

Προσέχετε όταν χειρίζεστε αυτόν τον μεντεσέ, διότι το ελατήριο είναι πολύ δυνατό και μπορεί να προκαλέσει τραυματισμό.

### **Русский**

Внимание!

Будьте осторожны при обращении с этой петлей, так как пружина очень прочная и может причинить вред.

### **українська**

Застереження!

Обережно встановлюйте цю завісу, оскільки пружина дуже туга й може травмувати.

### **Srpski**

Upozorenje!

Pažljivo rukuj ovom šarkom jer je opruga veoma jaka i može izazvati povredu.

### **Slovenščina**

Opozorilo!

S to odmično spono ravnaj previdno, saj je vzmet zelo močna in lahko povzroči telesne poškodbe.

### **Türkçe**

Uyarı!

Yayın çok güçlü olduğunu ve yaralanmalara sebep olabileceğini dikkate alarak menteşe ile çalışırken dikkatli olunuz.

### **中文**

警告!

处理合叶时应小心谨慎，弹簧力度很强，可能会导致受伤。

### **繁體**

警告!

請小心使用鉸鏈，因彈簧的彈力強，可能會造成傷害。



### 한국어

경고!

경첩을 다룰때 강한 스프링으로 인해 부상의 위험이 있으므로 주의해 주세요.

### 日本語

警告！

このヒンジは固いので、指などを挟まないよう、お取り扱いには十分ご注意ください。

### Bahasa Indonesia

Peringatan!

Berhati-hati ketika mengendalikan engsel karena pegas yang kuat dan dapat menyebabkan cedera.

### Bahasa Malaysia

Awas!

Berhati-hati semasa mengendalikan engsel kerana springnya amat kuat dan boleh menyebabkan kecederaan.

### عربي

تحذير!

احذر عند مناولة هذه المفصلة حيث أن النابض قوي جداً وقد يسبب إصابات.

### ไทย

คำเตือน

ระวังขณะจับหรือใช้งานบานพับ เนื่องจากสปริงของบานพับแข็งมากจนอาจทำให้เกิดอันตรายได้

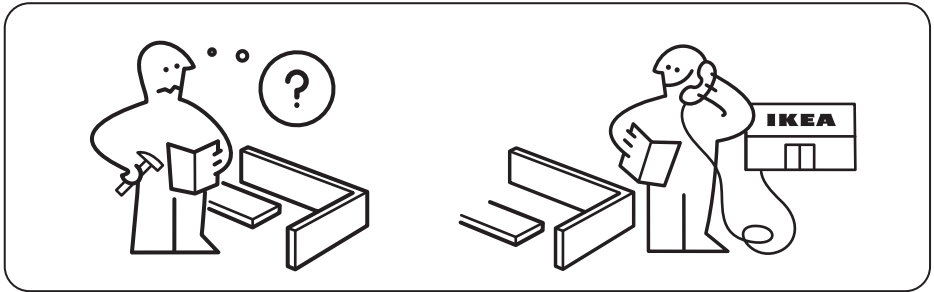
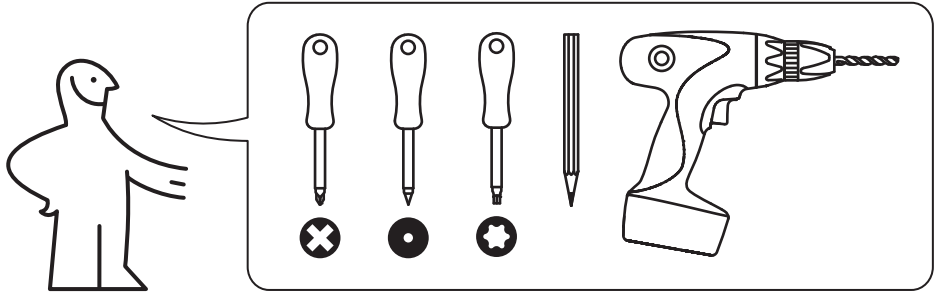

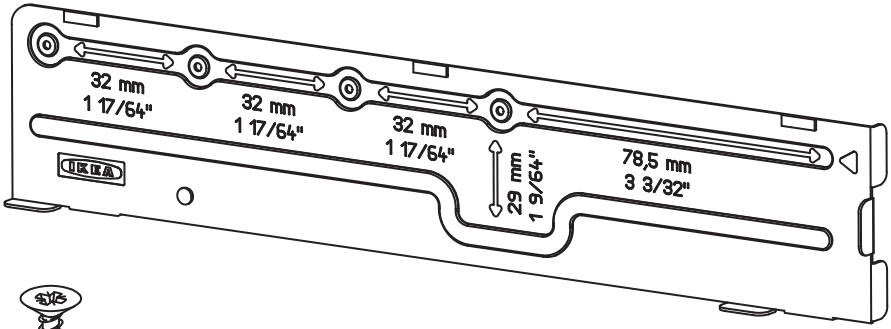

10050783

1x

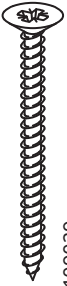

6x



8x



1x



1x

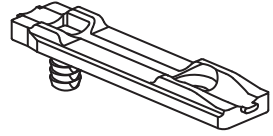

1x

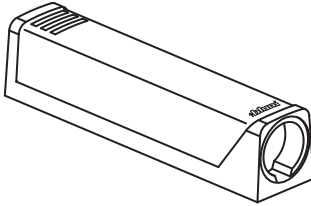

1x

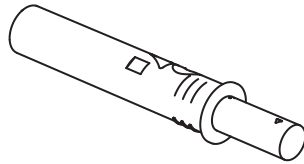

1x

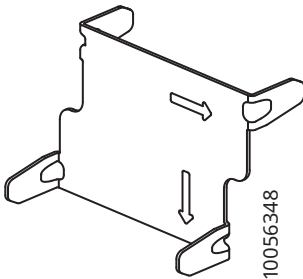

1x

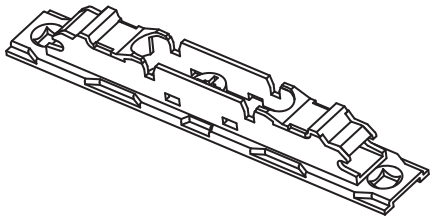

2x

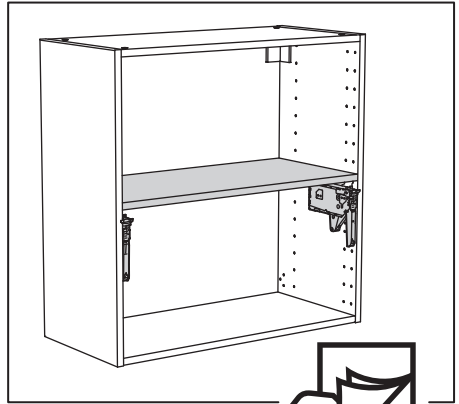
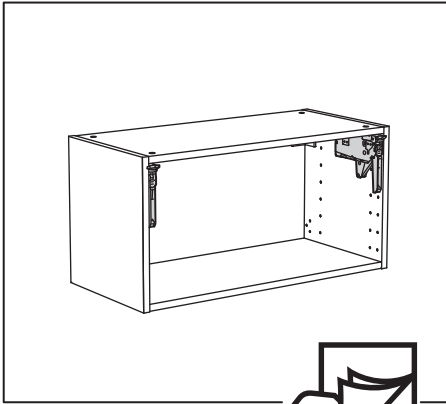

1

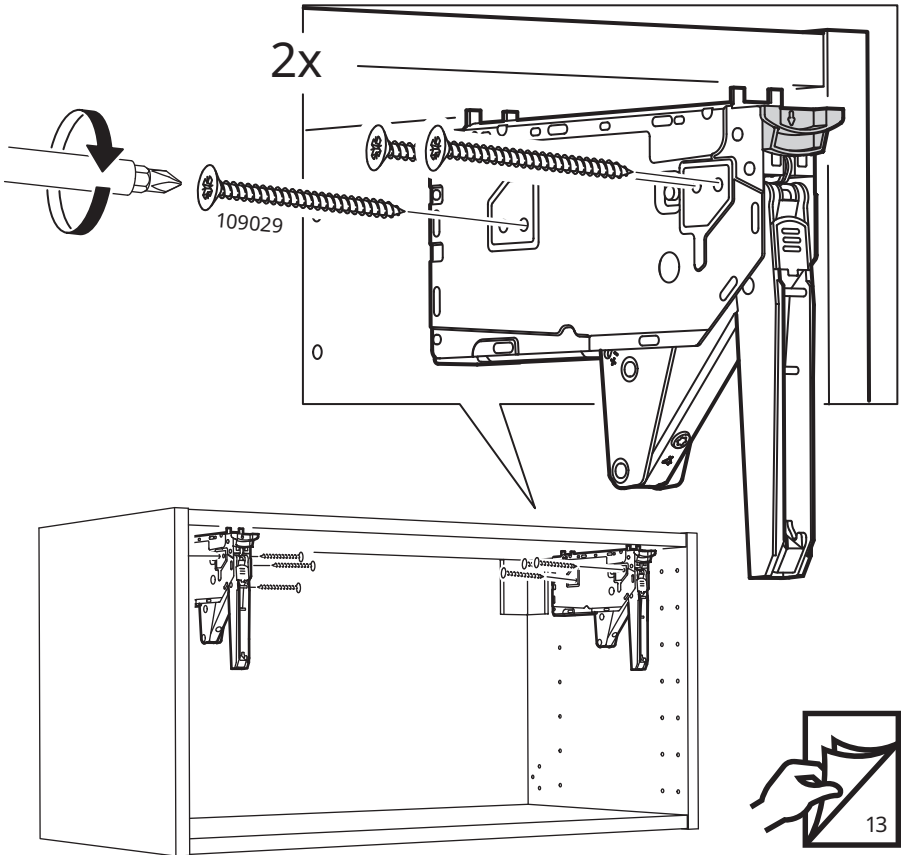
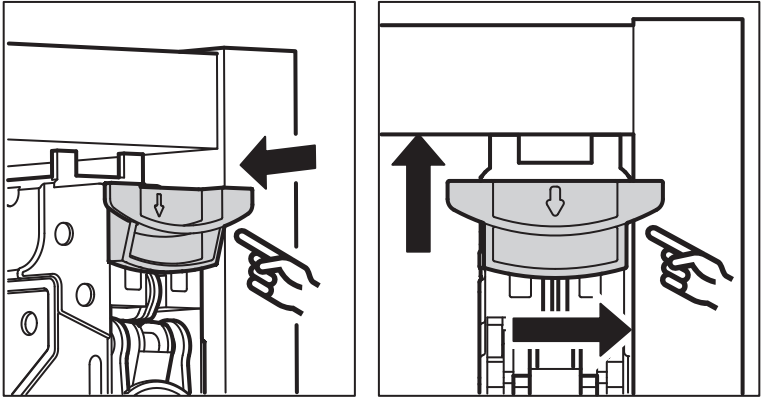



1

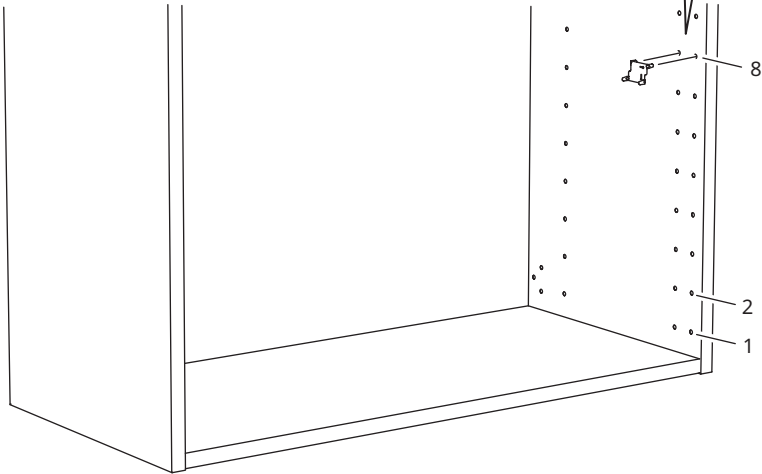
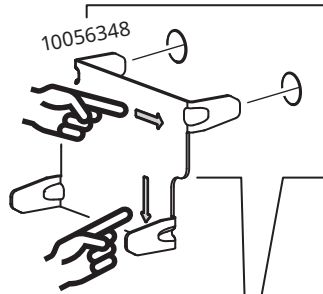
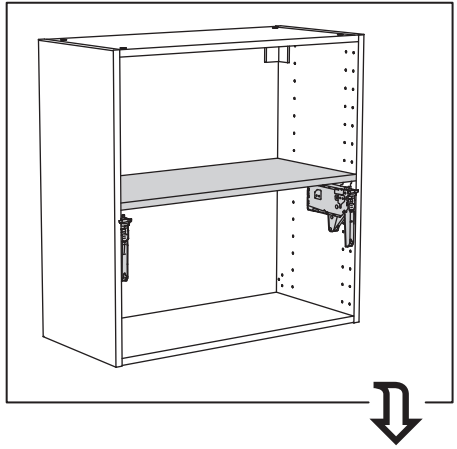

2

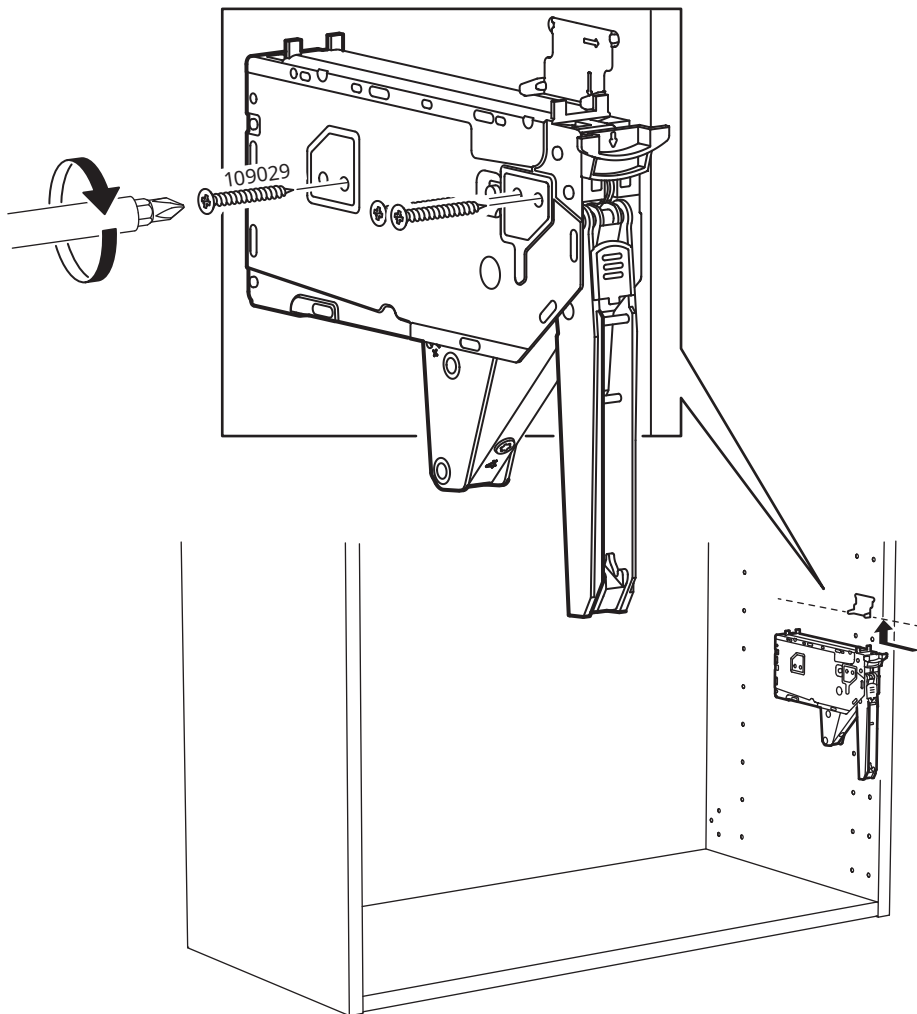
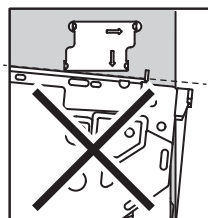
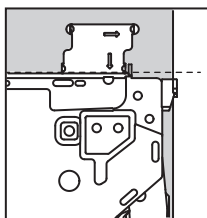
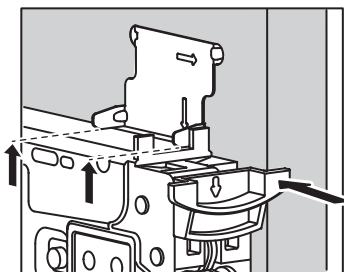

# 3

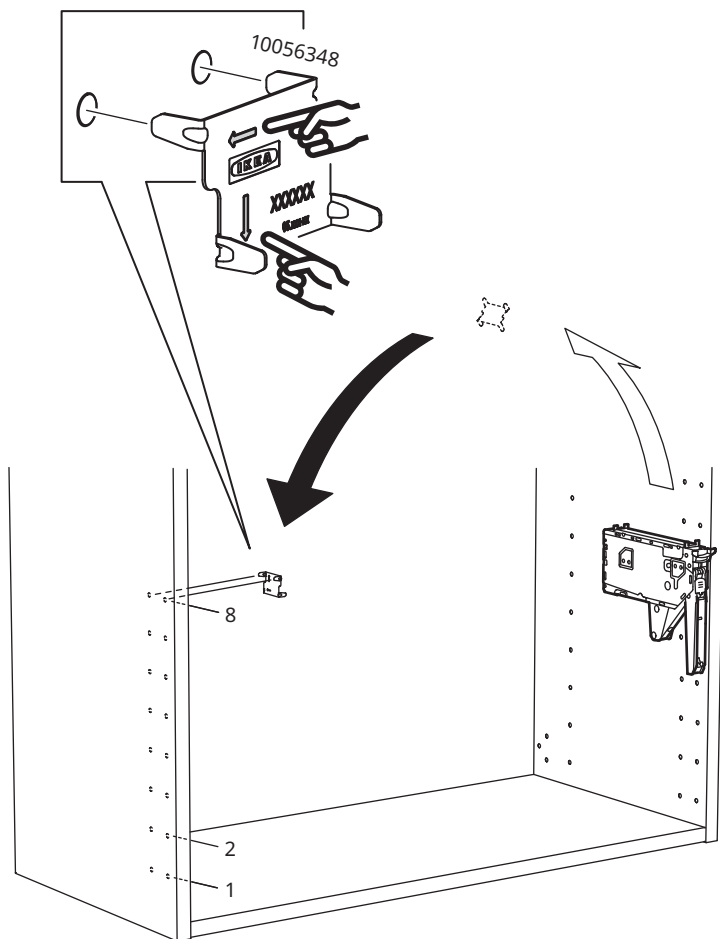

4

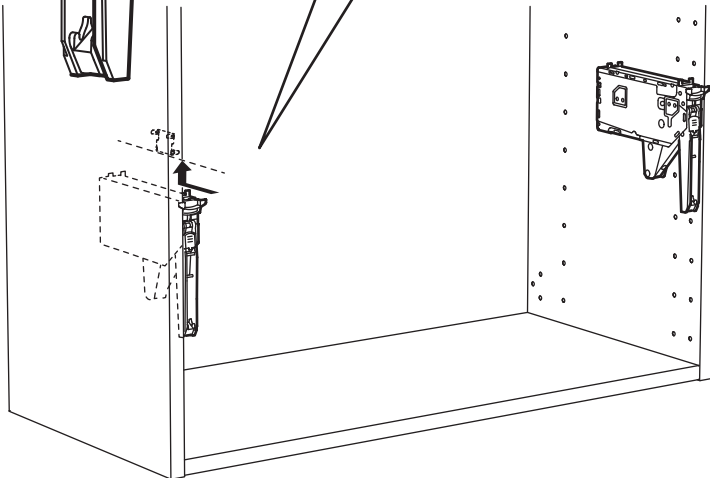
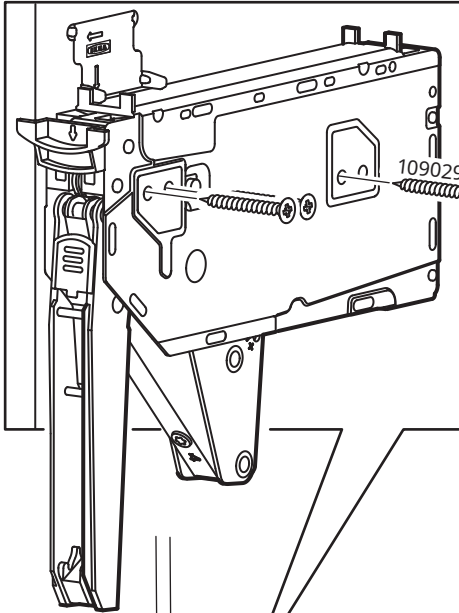
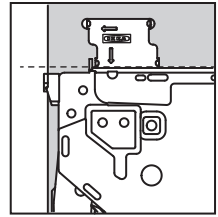
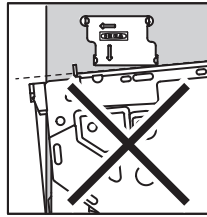
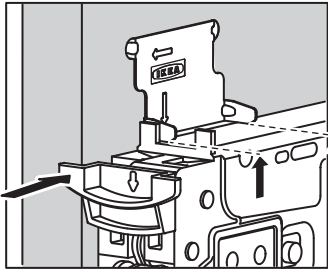

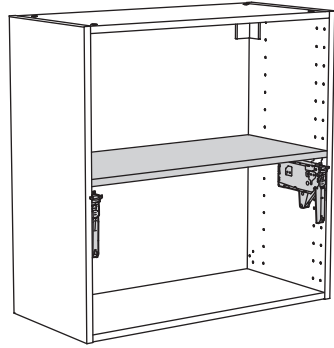
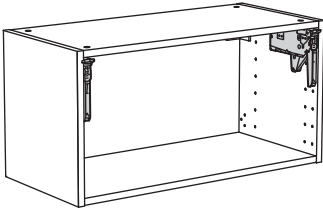

⇓  
5

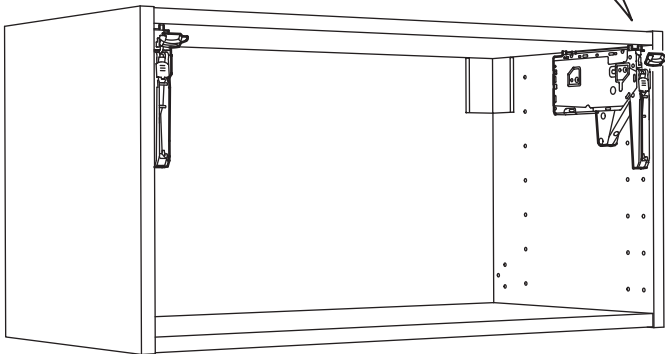
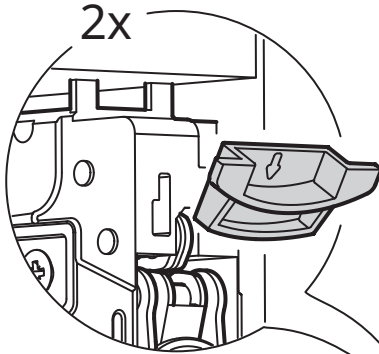

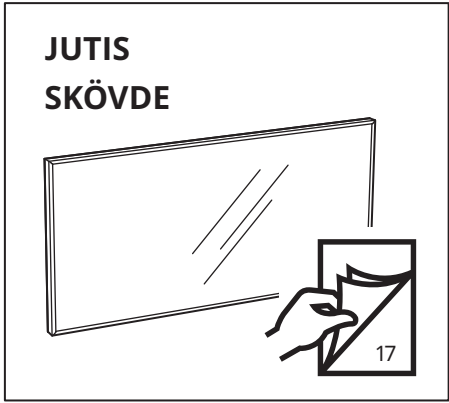
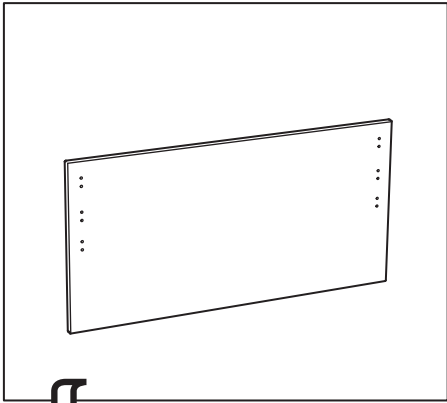

⇓  
**6**

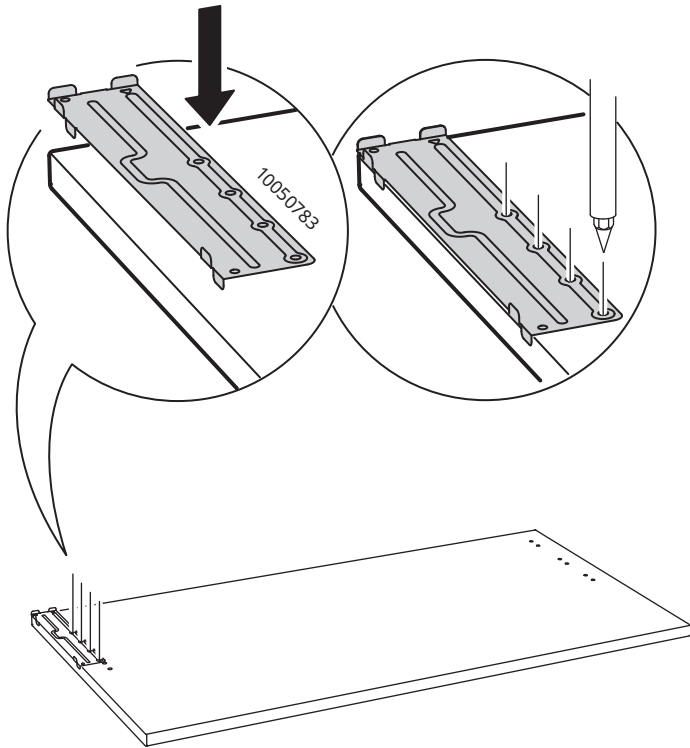

7

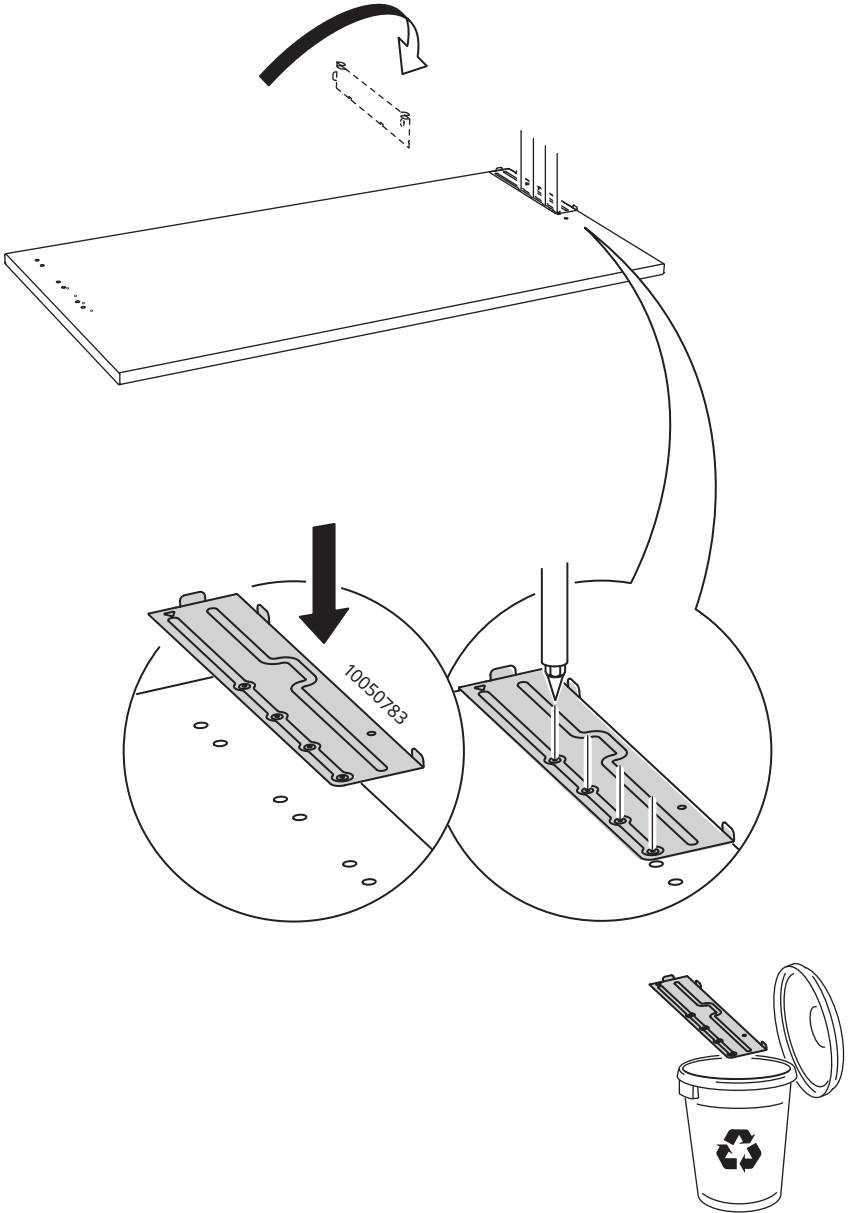

8

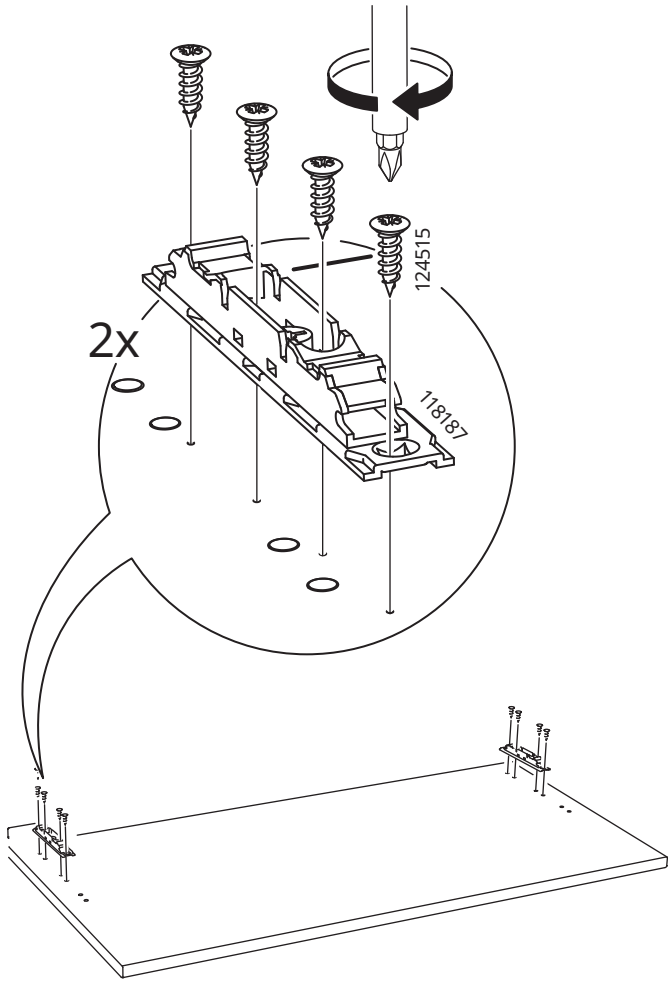



**JUTIS  
SKÖVDE**

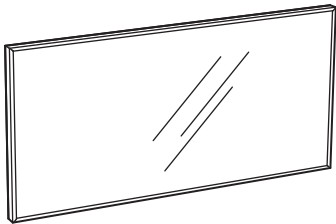

**6**

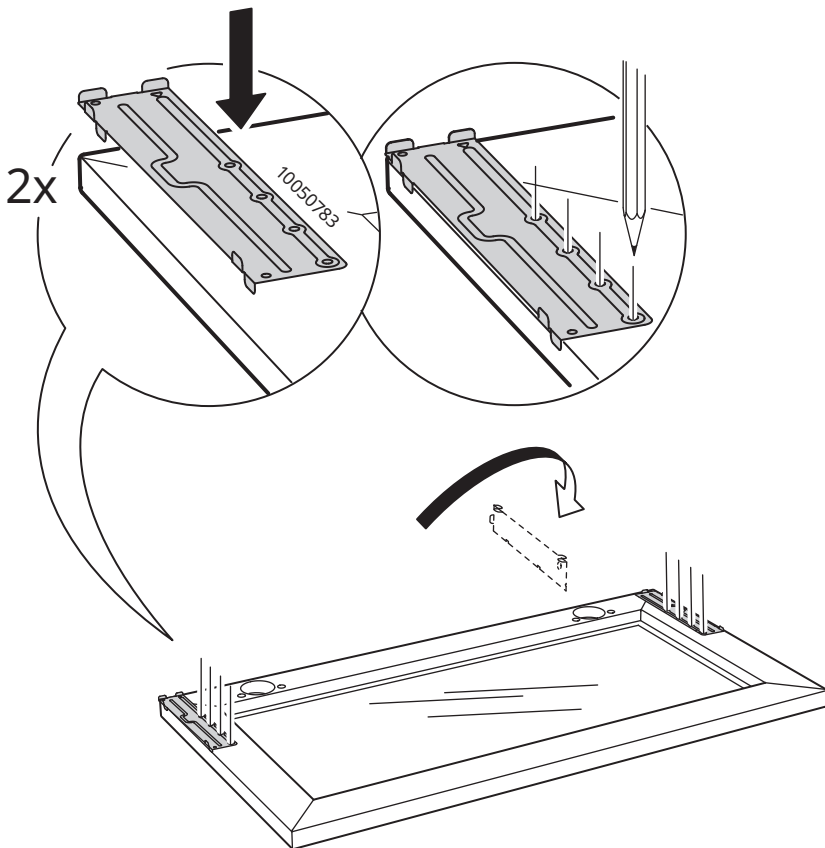

7

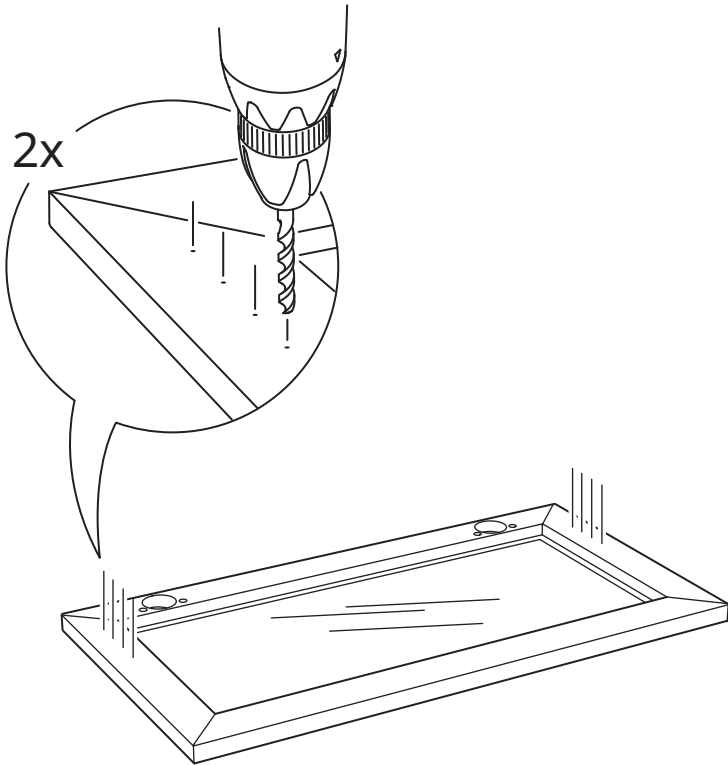
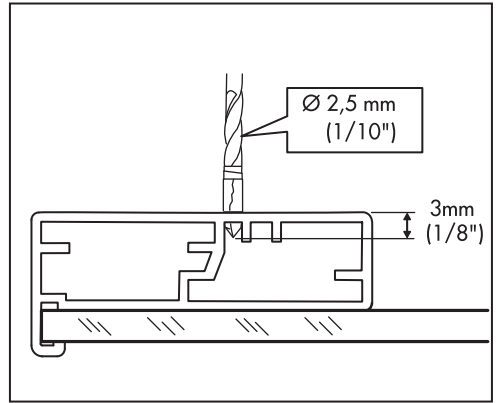

8

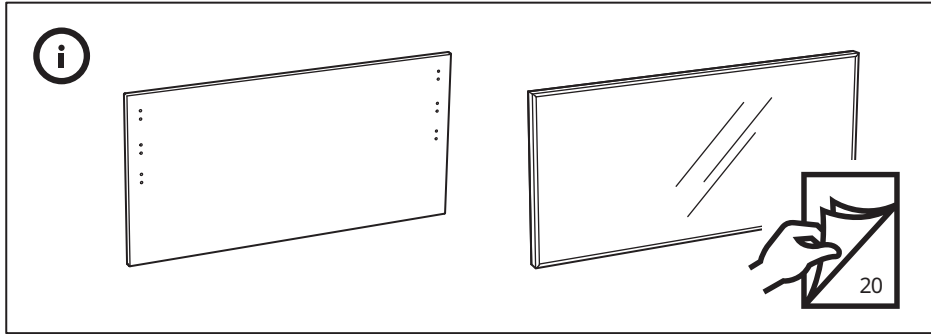
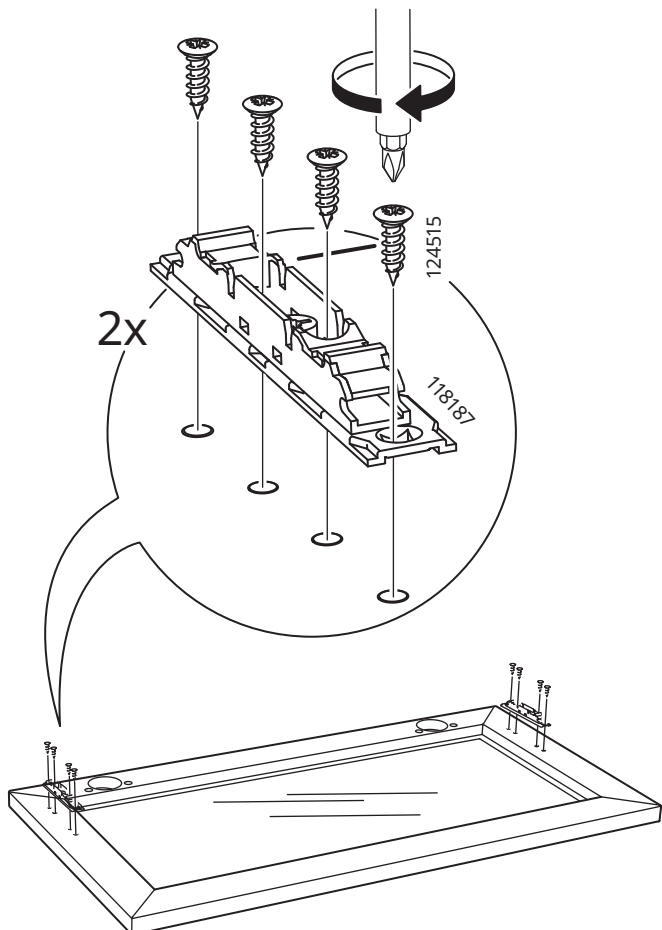

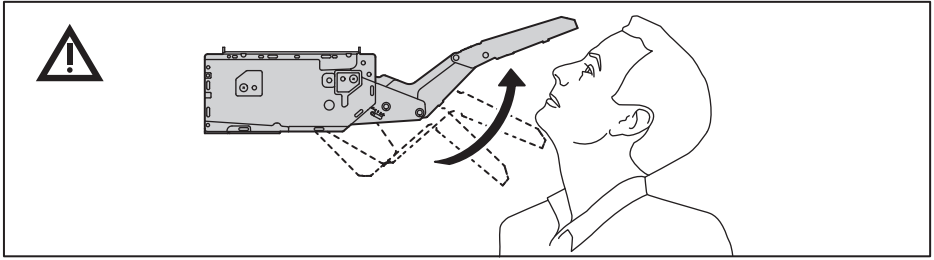

9

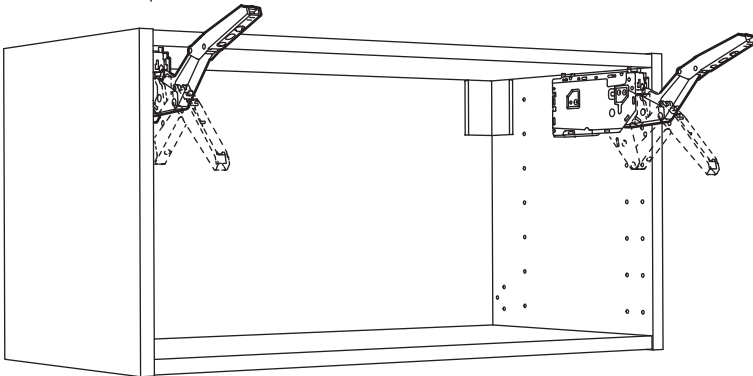
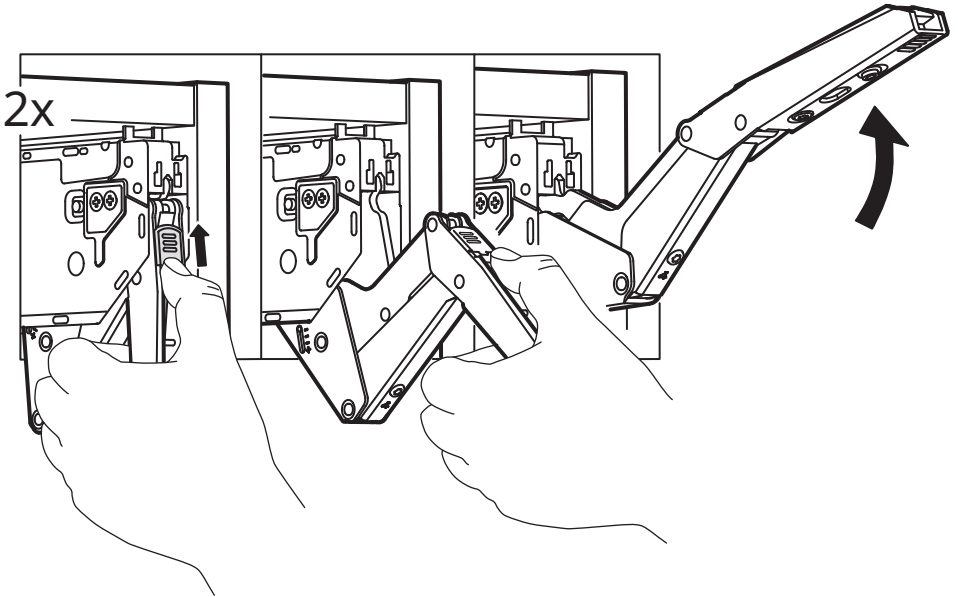

# 10

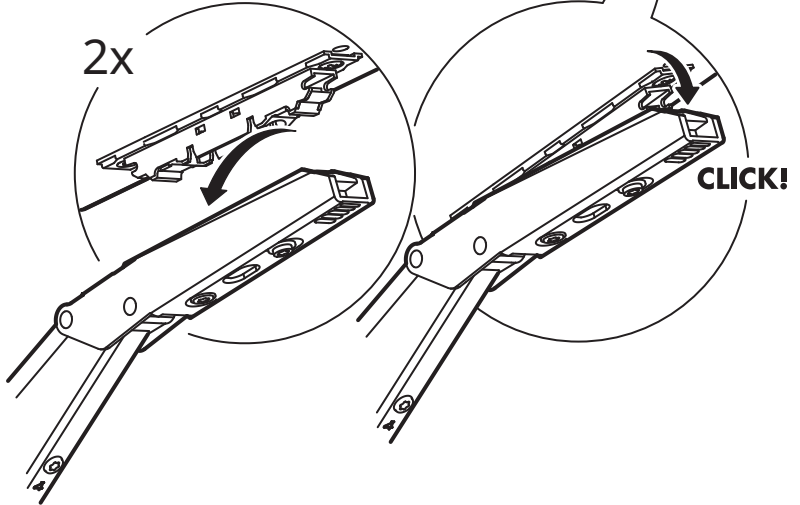
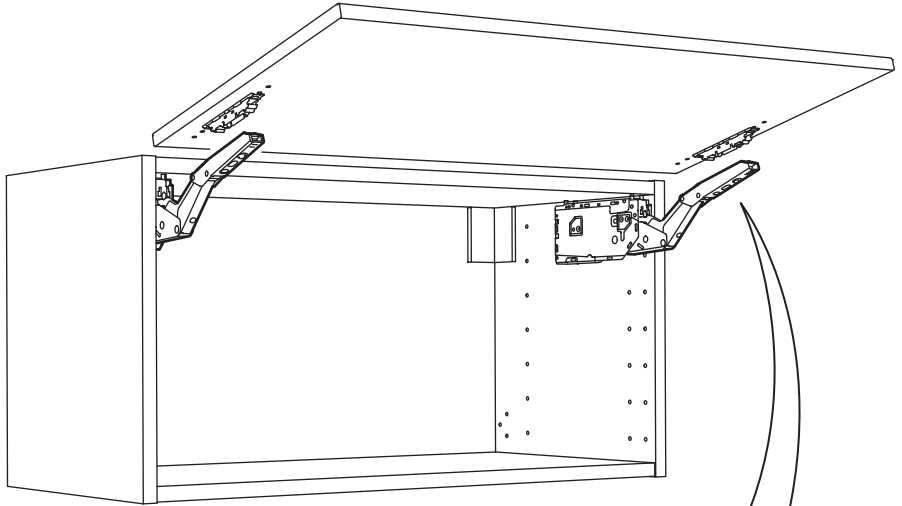

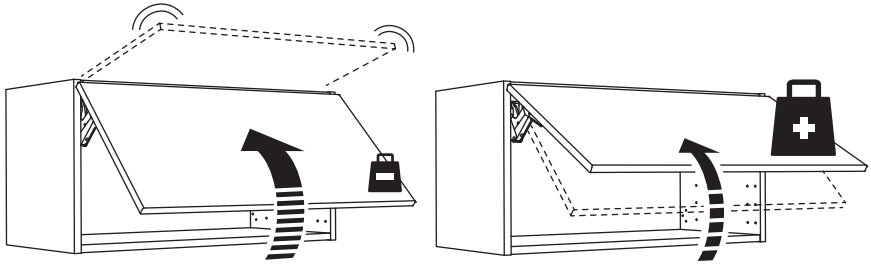

11

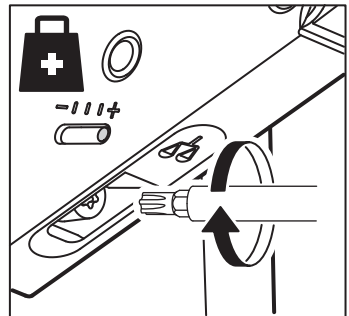
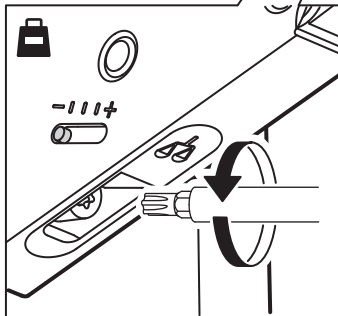
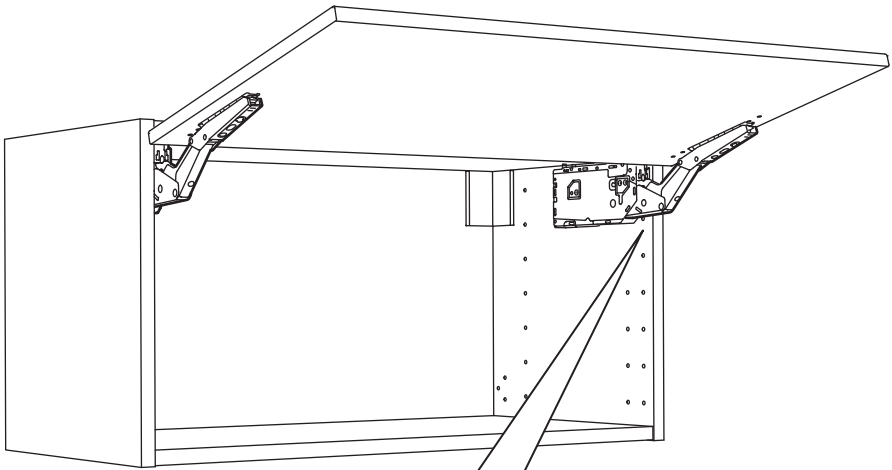

# 12

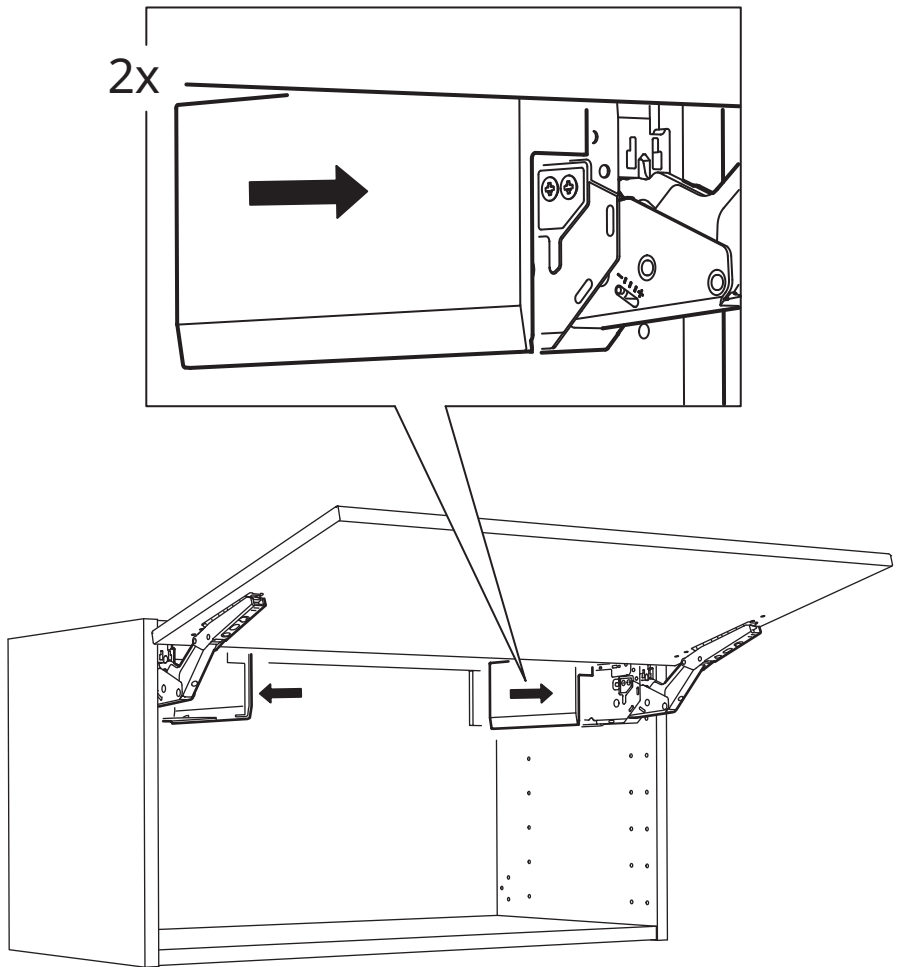

# 13

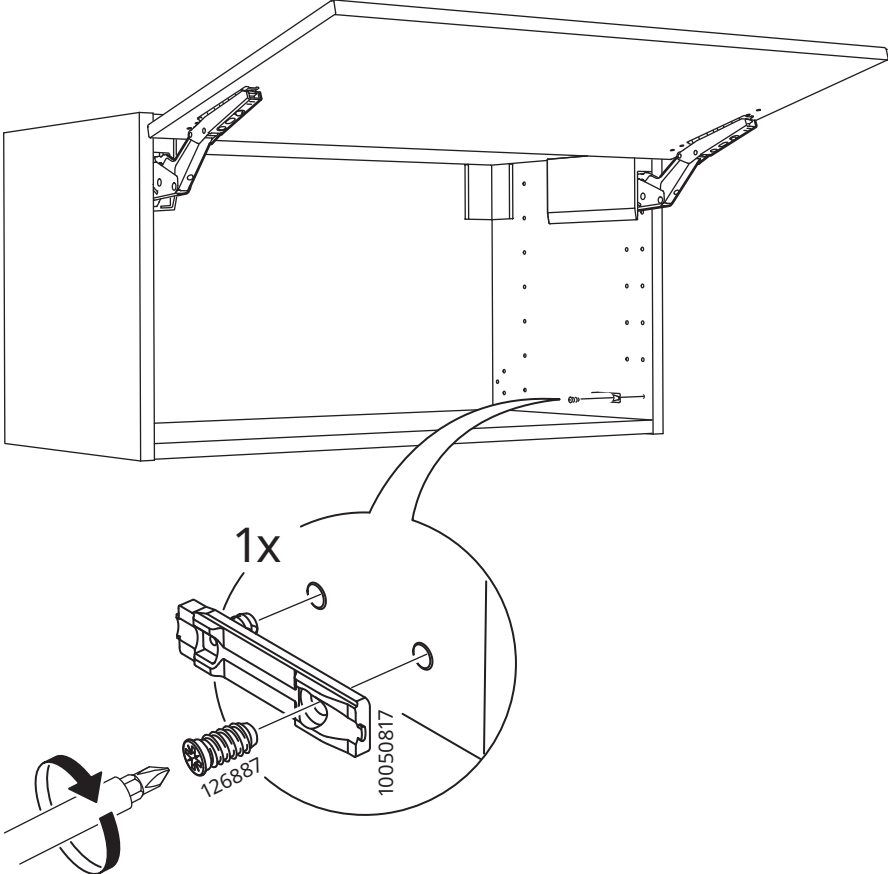



# 14

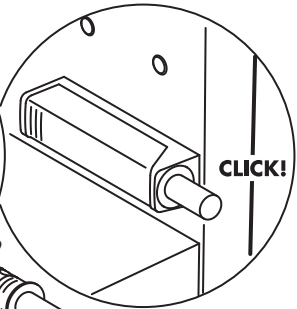
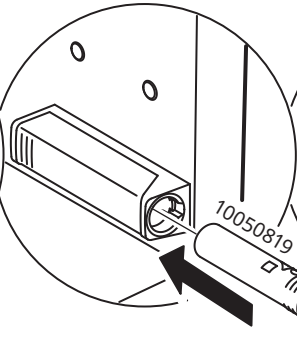
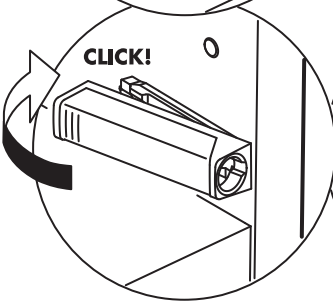
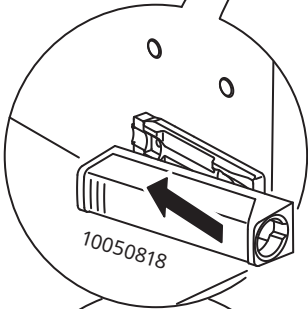
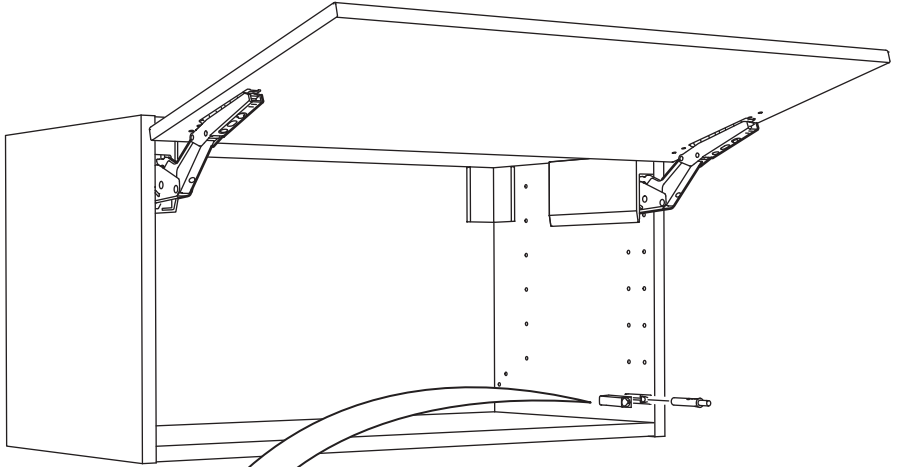

# 15

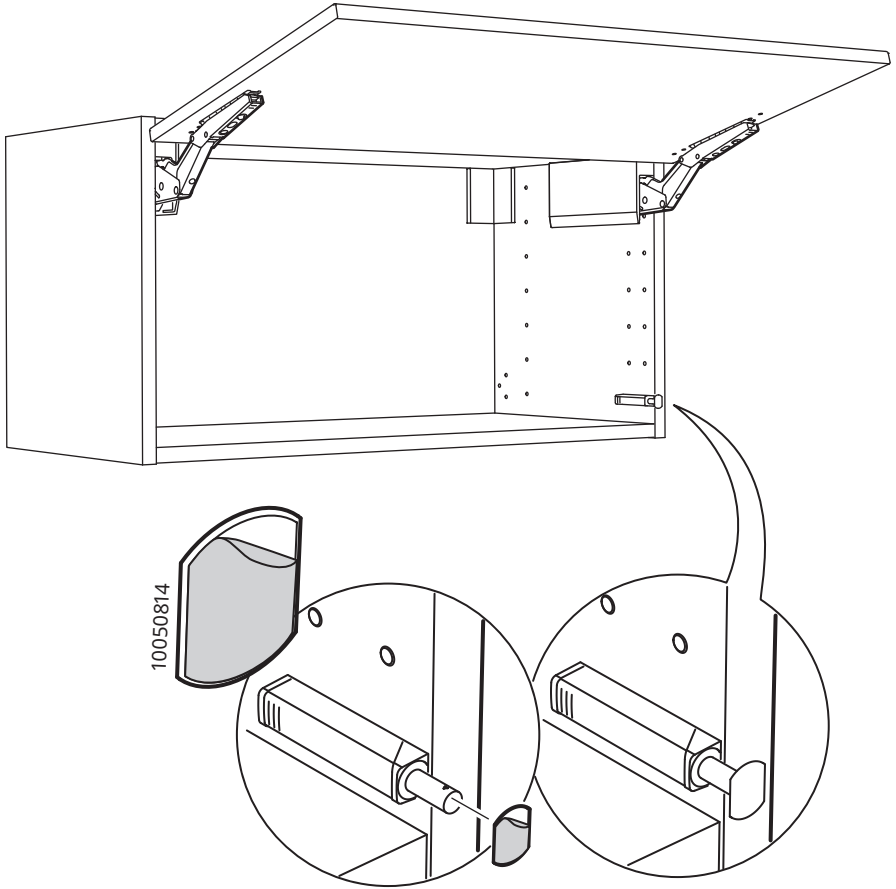

16

